

OWNER'S GUIDE

Model No. 110 - 500

10 CENTS

ROTARY MOWER

WARRANTY

For one year from date of purchase, MTD Products, Inc., will replace for the original purchaser, free of charge, F.O.B. factory or authorized service firm, any part or parts found to be defective in material or workmanship. All transportation charges on parts submitted for replacement under this warranty must be paid by the purchaser. This warranty does not include replacement of parts which become inoperative through misuse, excessive use, accident, neglect, improper maintenance or alterations by unauthorized persons. This warranty does not include the engine, motor, battery, battery charger or any component parts thereof. For service on these units refer to the applicable manufacturer's warranty.

The above warranty will apply only to the original owner and will be effective only if the warranty card has been properly processed. It will not apply where the unit has been used commercially.

Warranty service is available through your local authorized service dealer or distributor. UNDER NO CIRCUMSTANCES WILL THE RETURN OF A COMPLETE UNIT BE ACCEPTED BY THE FACTORY UNLESS PRIOR WRITTEN PERMISSION HAS BEEN EXTENDED.

SAFETY RULES

Your rotary mower is a precision piece of power equipment, not a plaything. Therefore exercise extreme caution at all times.

1. Remove all sticks, stones, wire and other hazardous items from lawn before mowing. Such items are dangerous to both the mower and individuals in the vicinity of the mower.
2. Always disconnect spark plug cable during repairs or refueling operations.
3. Always start engine from side opposite discharge chute.
4. NEVER place hands or feet under mower or near discharge chute while engine is running.
5. Do not tilt mower at extreme angle while engine is running. Cut grass on hills and banks sideways, not up and down.
6. Always stop engine when not cutting grass.
7. Do not fill gas tank while engine is running. Do not spill gasoline on hot engine.
8. Keep children and pets away from area at all times during mowing operation. Never allow mower to discharge grass toward any person.
9. Do not attempt to start engine while mower is resting in high grass.
10. Check all nuts and bolts, particularly the blade bolts, for tightness. This is especially important during the initial operation period. Make this same check periodically.
11. While operating the mower, if any foreign object is struck, stop the mower and inspect for damage. Do not restart or operate the mower until all damage has been repaired.

WARNING: Should excessive vibration develop, check your blade and crankshaft immediately. Do not operate mower with an unbalanced blade, a damaged blade or a damaged crankshaft.

110 - 500

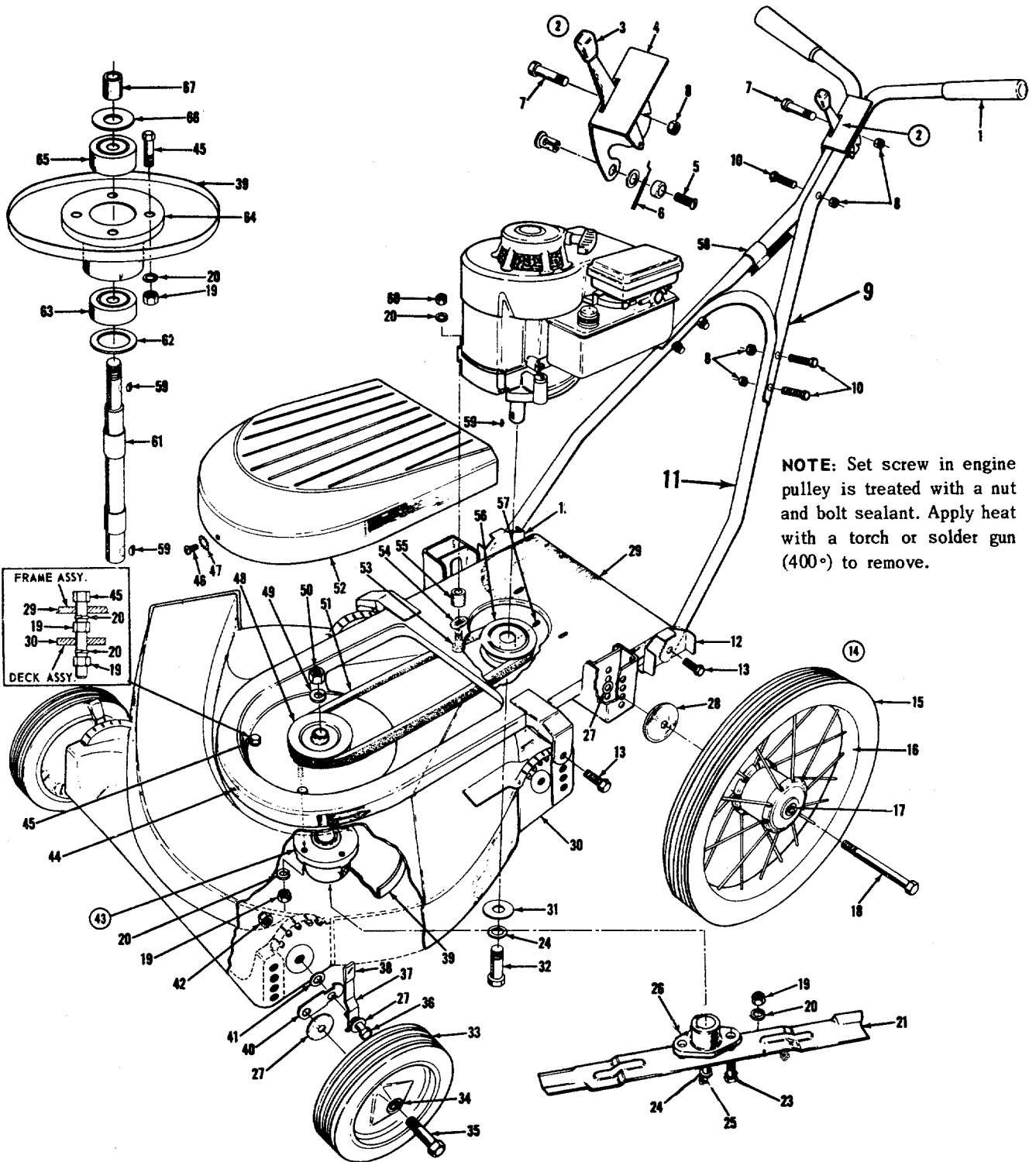

NOTE: Set screw in engine pulley is treated with a nut and bolt sealant. Apply heat with a torch or solder gun (400°) to remove.

PARTS LIST FOR MODEL NO. 110-500

Ref. No.	Part No.	DESCRIPTION	Ref. No.	Part No.	DESCRIPTION
1	305-7072	Grips - White	36	710-191	Hex Hd. Cap Scw. 3/8-24 x 1-1/4 lg. (Heat Treated)
2	310-8846	Throttle Control - Complete	37	310-8835	Spring Lever Assembly
3	305-7470	Knob +	38	305-7520	Knob - Red
4	310-8841	Throttle Control Bracket +	39	347-8809	Blade Reinforcement Plate
5	901-7627	Ferrule Assembly +	40	310-7492	Wheel Pivot Ba
6	732-139	Conduit and Wire +	41	736-133	Flat Washer 3/8 ID *
7	710-606	Hex Hd. Cap Scw. 1/4-20 x 1-1/2 lg. *	42	712-116	Elastic Stop Nut 3/8-24 thread *
8	712-107	Hex Centerlock Nut 1/4-20 thread *	43	901-7805	Blade Spindle Ass'y - Complete
9	310-9364	Handle - Upper (2 Req'd)	44	712-526	Speed Nut
10	710-106	Hex Hd. Cap Scw. 1/4-20 x 1-1/4 lg. *	45	710-116	Hex Hd. Cap Scw. 5/16-18 x 2 lg. *
11	310-8334	Handle - Lower	46	710-473	Truss Hd. Mach. Scw. #10-24 x 1/2 lg. *
12	310-9060	Handle Bracket	47	736-147	External Lockwasher #10 Screw *
13	710-209	Sems Hex Hd. Cap Scw. 3/8-16 x 5/8 lg. *	48	310-9925	Pulley - 4" dia. - 1/2" bore
14	501-9184	Wheel Assembly - Rear	49	736-921	Spring Lockwasher - 1/2" screw *
15	734-237	Tire - Rib Tread 14" dia. x 1-3/4"	50	712-922	Hex Jam Nut 1/2 - 20 thread *
16	734-238	Wheel Assembly - Rear Tire	51	754-116	V-Belt 42" x 1/2" *
17	748-147	Flange Bearing (2 Req'd Per Wheel)	52	347-8295	Blade Spindle Cover
18	738-114	Axle Bolt - Rear	53	710-158	Hex Hd. Cap Scw. 5/16-24 x 1-1/4 lg.
19	712-123	Hex Nut 5/16 - 24 thread *	54	736-170	Lockwasher - Special
20	736-119	Spring Lockwasher 5/16 Screw *	55	711-250	Spacer
21	312-8125	Blade - 21"	56	756-121	Pulley - Engine - 4" dia.
23	710-117	Hex Hd. Cap Scw. 5/16-24 x 1 lg. (Heat Treated)	57	710-938	Allen Set Scw. Cup Pt. 1/4-28 x 1/4 lg. *
24	736-169	Spring Lockwasher - 3/8" Screw *	58	746-145	Cable Clip
25	710-113	Hex Hd. Cap Scw. 3/8-24 x 1-5/8 lg. (Heat Treated)	59	714-365	Key-Hi Pro #HP 505 * ▲
26	748-100	Blade Adapter	60	712-267	Hex Nut 5/16-18 thread *
27	736-105	Belleville Washer	61	711-240	Spindle ▲
28	736-112	Belleville Washer	62	721-105	Seal ▲
29	347-9169	Frame Assembly	63	741-107	Timken Bearing - 3/4 Bore - lower ▲
30	347-9069	Deck Assembly	64	719-120	Spindle Housing ▲
31	310-7386	Washer	65	741-120	Timken Bearing - 11/16 Bore - upper ▲
32	710-152	Hex Hd. Cap Scw. 3/8-24 x 1 lg.	66	736-154	Flat Washer ▲
33	510-9392	Wheel Assembly - Front	67	711-212	Sleeve ▲
34	305-7006	Fortiflex Bearing			
35	738-213	Axle Bolt			

* For faster service obtain standard nuts, bolts and washers locally. If these items cannot be obtained locally, order by part number and size as shown on parts list.

+ Included in Part No. 310-8846 Control-Throttle (complete).

▲ Included in Part No. 901-7805 Blade Spindle Ass'y (complete).

ASSEMBLY

Your new mower is shipped completely assembled with the exception of the handle.

1. Remove lawn mower and all parts from carton. Make certain that all loose parts and literature are removed from carton before carton is discarded.
2. Extend throttle control assembly, which is attached to rear of mower and place on floor. CAUTION: Do not bend or kink control wire.
3. (a) Snap lower handle into position on two lugs which extend from the handle brackets mounted on the rear of the frame assembly.
 - (b) Assemble the two upper handle parts with cap screws and locknuts provided in parts bag. The yellow cap screw should be used to attach throttle control assembly to upper handle as shown in diagram. Do not tighten nuts.
 - (c) Attach upper handle assembly to lower handle with cap screws and locknuts. Tighten all nuts.
 - (d) Secure control wire to lower handle with cable clips.
4. Check blade bolts for proper tightness.
5. See initial belt adjustment under Adjustment Section on page "D".

OPERATION

NOTE: For shipping purposes your mower is set with the wheels in a low cutting height position. For best results raise the cutting position until it is determined which height is best for your lawn. See adjustments.

1. Service engine with gas and oil. See Engine Manual packed with lawn mower for complete instructions for the care and maintenance of engine. *Read Directions Carefully.*
2. When ready to start engine, place throttle control lever, on handle, in "Choke" position and start engine in accordance with instructions in Engine Manual. After engine starts, move throttle control lever, on handle, to desired engine speed. The engine is stopped by placing control lever on handle in the "Stop" position.
3. Be sure that lawn is clear of stones, sticks, wire or other objects which could damage lawn mower or engine. For best results and to insure more even grass distribution, do not mow when lawn is excessively wet.

ADJUSTMENTS

CAUTION: Do not at any time make any adjustment to lawn mower without first stopping engine and disconnecting spark plug wire.

CUTTING HEIGHT – An adjusting plate and thumb lever at each front wheel position provides cutting height adjustment. Each adjusting plate has five holes. Height of cut will be changed when the thumb lever is moved from one hole to another. Simply depress thumb lever towards wheel and move wheel and lever assembly to desired position. Cutting height will be raised as lever is moved toward front and lowered as lever is moved toward rear.

Adjustment may be made to the rear wheels by removing and moving wheel studs to desired position. Cutting heights will be raised as wheel studs are moved to a lower hole and lowered as wheel studs are moved to a higher hole in the deck. All wheels must be positioned in relative height of cut positions.

THROTTLE – If adjustment becomes necessary, the throttle control wire assembly can be reset as follows:

1. Loosen, but do not remove, screw securing throttle control wire assembly at engine.
2. Move throttle control lever on handle to "CHOKE" position.
3. Move lever, to which control wire is fastened at engine, to full choke position and retighten screw to secure throttle control wire assembly.

BELT ADJUSTMENT – After the first one-half hour of operation the slack in the belt must be taken up. After this initial adjustment the belt will require only checking after every 25 hours of operation. To tighten the belt, remove the three truss head machine screws (46) and lockwashers (47) and remove the blade spindle cover (52). Loosen the three hex nuts (60) holding the engine to the frame assembly (29) and pull the engine back until the belt (51) has a 1/4" deflection when depressed by hand. Tighten the hex nuts (60) and reassemble shroud.

MAINTENANCE

CUTTING BLADE – The blade may easily be removed for grinding or replacement as follows:

1. Remove bolt and lock washer holding blade and hub assembly to blade spindle.
2. Remove blade and hub assembly from blade spindle.
3. Remove two bolts, lock washers and nuts holding blade to blade hub.

When sharpening blade, follow the original angle of grind as a guide. It is extremely important that each cutting edge receives an equal amount of grinding to prevent an unbalanced blade. An unbalanced blade will cause excessive vibration when rotating at high speeds and may cause damage to the mower.

Upon reassembly, make certain all parts are assembled properly and tightened securely.

DECK – The underside of mower deck should be cleaned after each period of use as grass clippings, leaves, dirt and other matter will accumulate. This accumulation of grass clippings, etc., is undesirable as it will invite corrosion and may cause an uneven discharge of grass clippings at the next cutting.

The deck may be cleaned by tilting the mower forward or on its left side and scraping clean with a suitable tool or by washing with a stream of water from a garden hose.

CAUTION: Do not direct the stream of water at a hot engine as damage to the engine may result.

STORAGE – The following steps should be taken to prepare lawn mower for storage.

1. Clean and lubricate mower thoroughly as described in the preceding instructions.
2. Refer to Engine Manual for correct engine storage instructions.
3. Coat mower's cutting blade with chassis grease to prevent rusting.
4. Place blocks under deck to raise tires clear of floor.
5. Store mower in a dry clean area.

LUBRICATION

IMPORTANT: Always stop engine and disconnect spark plug wire before cleaning, lubricating or doing any kind of work on lawn mower.

WHEELS – Front wheel bearings of Fortiflex require no lubrication. Rear wheels of Lifetime graphoil bearings require little lubrication. A light film of oil applied to these bearings will reduce normal friction.

THROTTLE – Periodically lubricate throttle control lever and throttle wire assembly with a few drops of light oil (S.A.E. No. 10 or 20) for ease of operation.

ENGINE – Follow Engine Manual for lubrication instruction.

USING YOUR ROTARY MOWER

For best results do not cut wet grass because it tends to stick to underside of the mower thus preventing proper discharge of grass clippings. If wet grass must be cut reduce engine speed and walking speed to help distribute the clippings more effectively.

New grass should be treated as wet grass, otherwise a normal walking speed is about the right pace for efficient mowing.

The best mowing pattern is one that allows the clippings to discharge towards the uncut part of the lawn. This permits recutting of the clippings to further pulverize them. When cutting high weeds, discharge towards cut portion then recut at right angles to first direction.

Lawn should be cut in the fall as long as there is growth.